

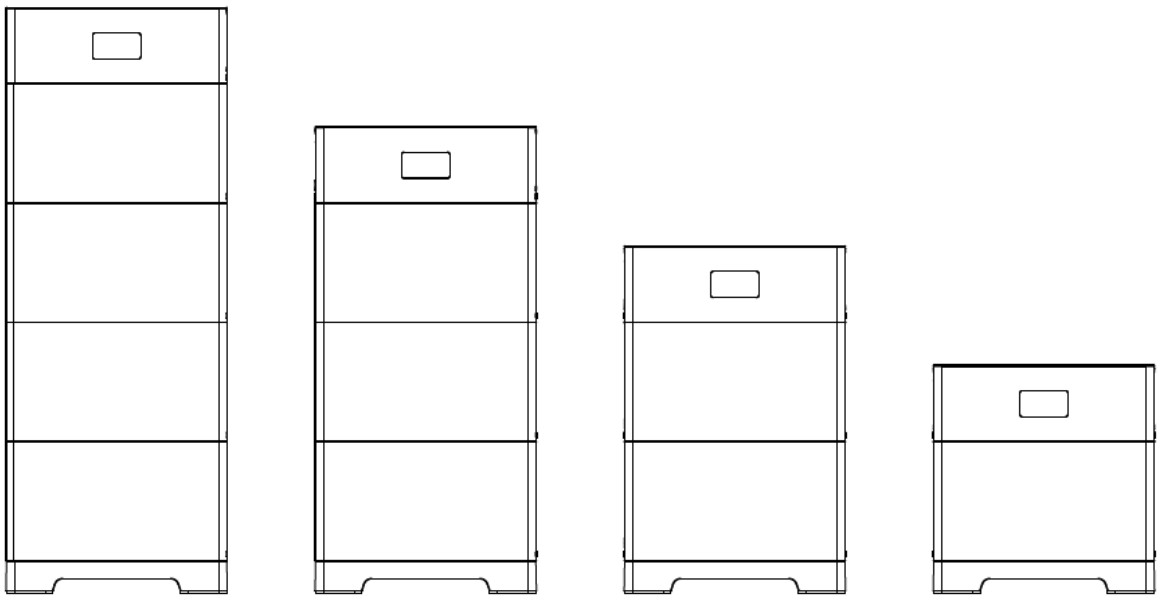

# User manual

Honror ES RY-5/10/15/20-S1 Series



Version: V1.1

# Content

1	Safety precaution .....	3
1.1	Storage and installation environment.....	3
1.2	Battery safety guidelines.....	3
1.3	Warning signs and stickers .....	3
1.4	Emergency handling.....	4
2	Product description.....	5
2.1	Product introduction.....	5
2.2	Appearance description .....	7
3	Installation guide.....	8
3.1	Environmental requirements .....	8
3.2	Installation physical requirements .....	9
3.3	Installation.....	11
3.3.1	Installation tools.....	11
3.3.2	Packaging components.....	12
3.4	Installation steps .....	13
4	Electrical connections .....	22
4.1	Grounding instructions.....	22
4.2	Power connector installation .....	23
4.3	Cable connection.....	24
4.3.1	Single Honor ES system.....	24
4.3.2	Multiple Honor ES in parallel .....	25
5	Power up your system.....	26
5.1	System power up.....	27
5.2	System power off .....	27
5.3	Display description.....	27
5.4	System configuration.....	28
6	Maintenance and troubleshooting .....	31
6.1	Routine maintenance .....	31
6.2	Fault checklist.....	31
7	Warehouse storage guidelines.....	33
7.1	Packaging guidelines .....	33
7.2	Storage .....	34
8	Dispose of used batteries.....	34
9	Detailed specifications .....	35

---

# 1 Safety precaution

Read the manual carefully and operate in accordance with the safety precautions. Refer to local safety regulations on items not covered in this manual. Electrical installation, maintenance must be performed by professional / qualified personnel.

## 1.1 Storage and installation environment











- Handle the product gently, prevent from dropping
- Avoid open flame; keep away from flammables, explosives or corrosive chemicals
- Choose cool and dry place for storage and installation
- Prevent from water or humid intrusion
- Prevent from accidental access (children and animals)
- Do not step on the product packaging.
- Do not place any foreign objects on top of the battery pack.
- Do not store the battery pack upside down

## 1.2 Battery safety guidelines







- Prevent from electrostatic discharge
- Wear insulating gloves when handling batteries.
- Do not energize auxiliary power during installation
- Check the polarity carefully before switching on the system
- Defected or damaged batteries shall not be charged or discharged.

## 1.3 Warning signs and stickers

---

	Warning Generic hazard		DO not mix with domestic
	Warning High Voltage - Electrical shock hazard		Please recycle
	No flame		This side up
	No stepping on		User manual
	Warning High temperature		Protective Earth (connector)

---

	Warning High Voltage Wait 5 min till fully discharged		Protective Earth (general identification)
	Do not short circuit (cut off power)		Keep away from children
	Fragile		Do not get wet

## 1.4 Emergency handling

Wear personal protective equipment (PPE) such as goggle, facemask, insulated gloves and boots. Evaluate the situation before taking remedy action. When it is safe to do so, disconnect external AC or DC power connection.

Damaged or deformed battery enclosure

Risk of chemical leakage (i.e. electrolyte) and internal short-circuit.



Warning

Deformed or severely damaged battery pack can lead to piercing of cell pouch (chemical leakage) or internal short-circuit (thermal runaway). The damaged battery pack can release toxic gas. Keep away from it.

In case of accidental skin contact, wash the skin thoroughly with soap and seek medical advice. For eye contact, wash under running water (~15 minutes) and require immediate medical attention.

Fire hazard

If the fire is not from the battery or not spread to the battery, use FM-200 or CO<sub>2</sub> fire extinguisher to put out the fire.

If the battery pack catches fire, do not attempt to put out the fire and evacuate immediately.

Seek medical in case of inhalation of pungent and toxic fumes.

Keep damaged batteries isolated and call your local fire department. Contact service for further support.

Water damage

Risk of electric shock and internal short-circuit. In case of splash or water spillage, when it is safe to do so, dry the product. If any part of the battery system is submerged, keep away from water.

Do not reuse the submerged battery. Contact a service for support.

---

## 2 Product description

Honor ES is a plug-in energy storage system compatible with majority PCS brands. This document provides product introduction, installation, commissioning, maintenance, troubleshooting, packaging and transportation information.

### 2.1 Product introduction

- Residential energy storage system with lithium iron phosphate (LFP) technology
- Modular design; single battery system with 5 to 20kWh (1 – 4 pcs battery)
- Indoor or outdoor installation (IP55)
- Expandable to 60kWh (3 Honor ES RY-5/10/15/20-S1 series connected in parallel)
- PCS communication interface: CAN or RS485
- Bluetooth and WiFi for Mobile APP (PowerLite)
- Advanced battery management system (BMS) provides data acquisition, status monitoring and control to ensure the safe and reliable operation of the system.

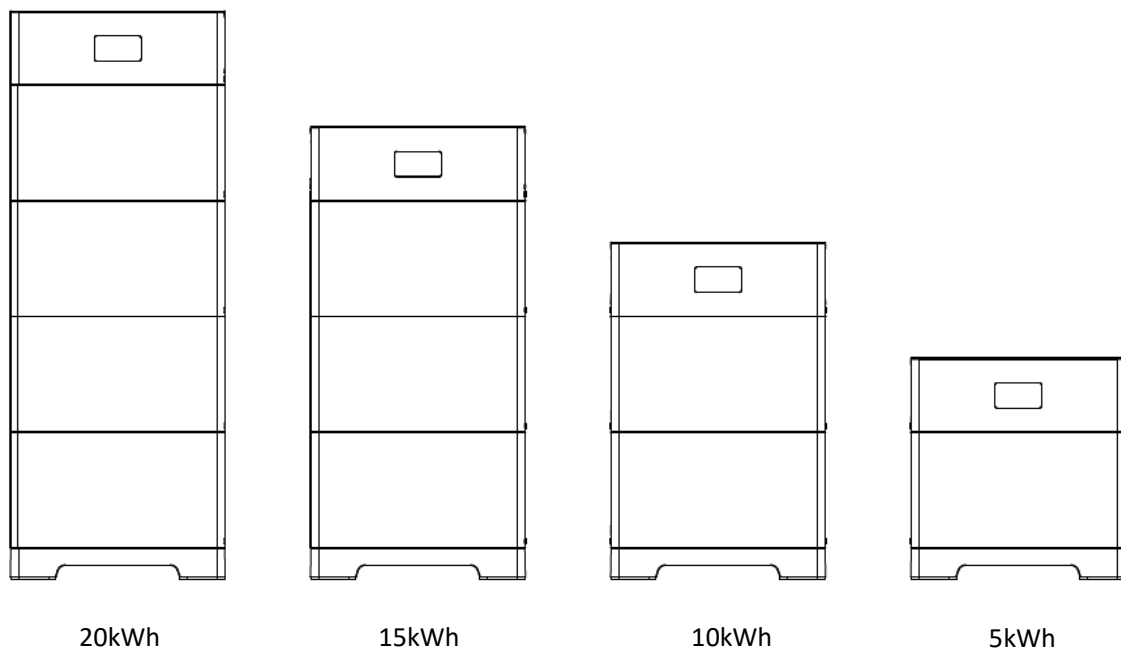

Figure 2-1-1 Honor ES configurations

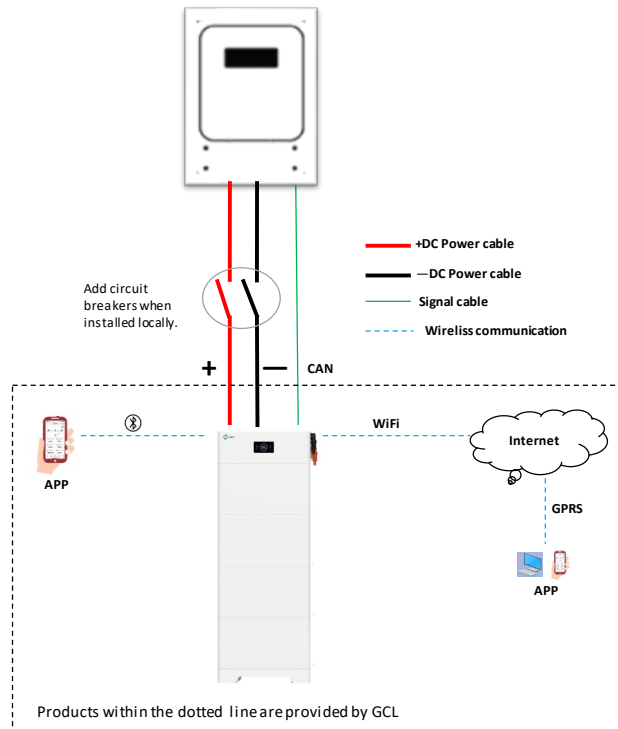

Figure 2-1-2 System topology

External circuit breaker required for AU market

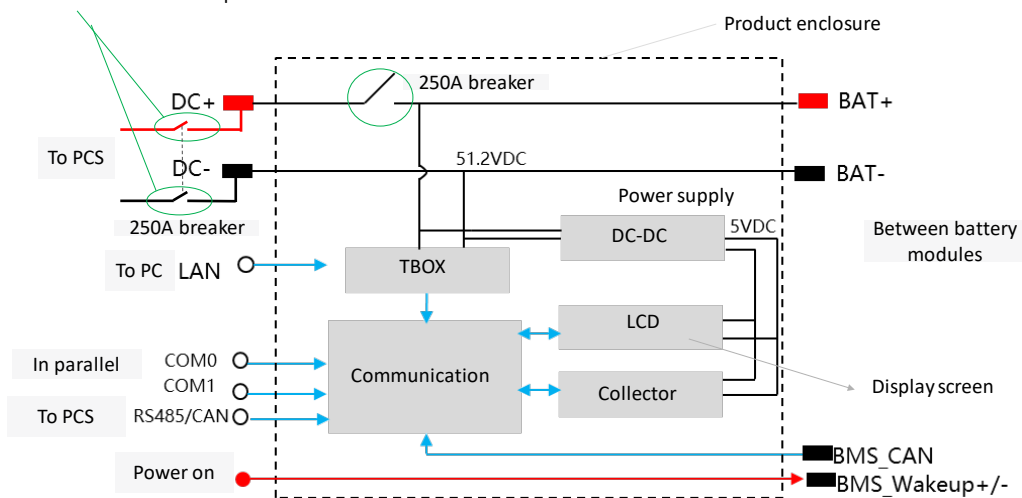

Figure 2-1-3 System Electrical schematic

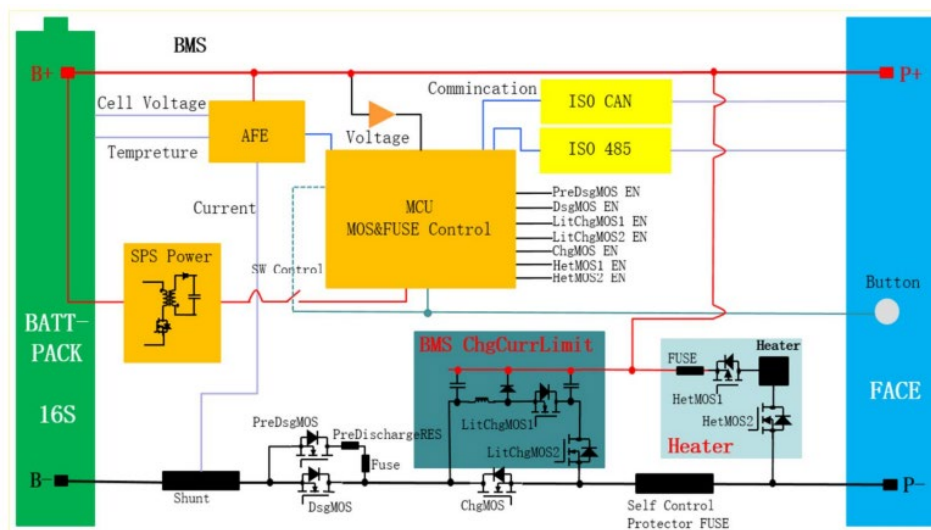

Figure 2-1-4 Isolation protection schematic between battery systems (with the battery negative is isolated by a self control protector fuse)

---

## 2.2 Appearance description

- Appearance of the whole system

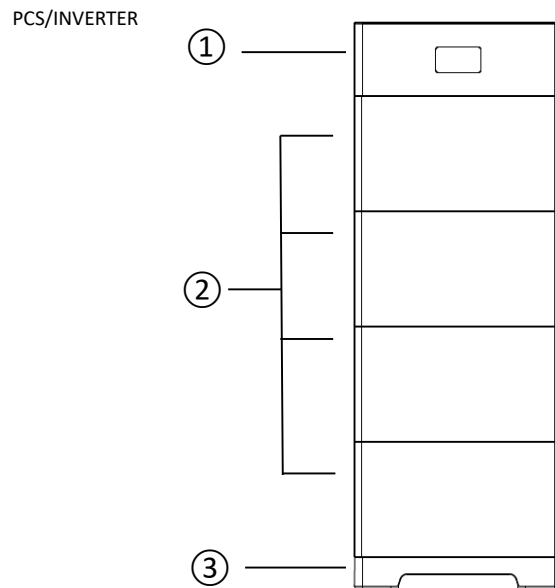

Figure 2-2-1 Appearance of the whole machine

- ① Control module      ② Battery module      ③ Mounting the base

- Control module

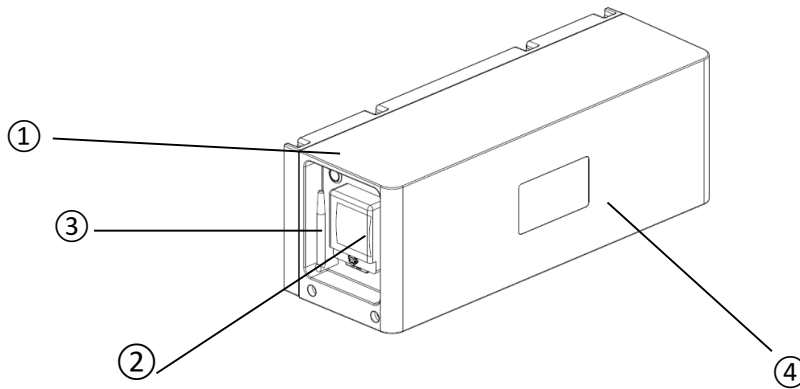

Figure 2-2-2 Left side of control module

- ① Power button      ② DC breaker      ③ Wi-Fi antenna      ④ display

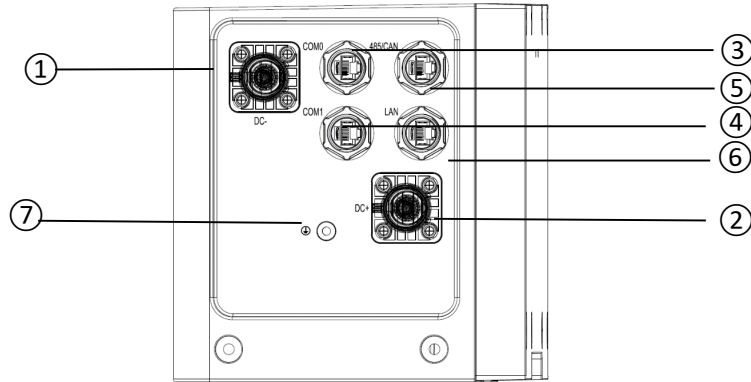

Figure 2-2-3 Right side of the control module

- ① Output Negative (DC-)
  - ② Output Positive (DC+)
  - ③ Parallel communication 0 (COM0)
  - ④ Parallel communication 1 (COM1)
  - ⑤ PCS communication (485/CAN)
  - ⑥ Maintenance (LAN)
  - ⑦ Protection earth (PE)
- Battery module

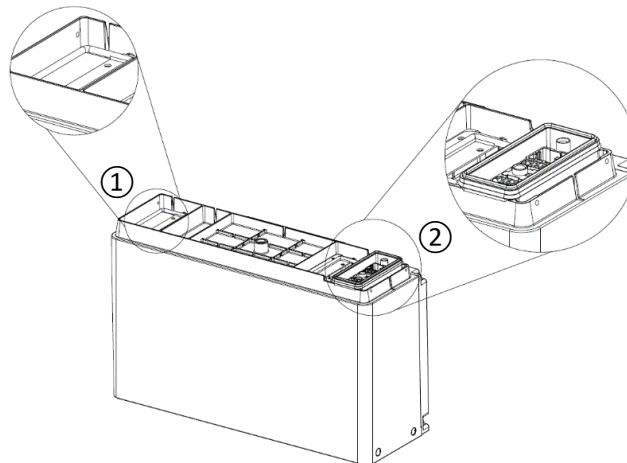

Figure 2-2-4 Structure diagram of battery module

- ① Handle
- ② Power/communication connector

### 3 Installation guide

#### 3.1 Environmental requirements

- a. Ambient temperature:  $-10^{\circ}\text{C}\sim+50^{\circ}\text{C}$  (recommended:  $10^{\circ}\text{C}\sim35^{\circ}\text{C}$  or  $50^{\circ}\text{F}\sim95^{\circ}\text{F}$ ).
- b. Ambient humidity: 10-95%.
- c. Altitude  $\leq 2000\text{m}$ .
- d. For outdoor installation
  - Avoid direct sunlight
  - Avoid rain and snow
  - Avoid location susceptible to flooding



- Install under shed if possible

e. For indoor installation

- 3 feet clearance from doors, windows, driveway or other batteries
- Keep away from heating device.
- Prevent from corrosive chemicals
- Prevent from water spillage
- Consider location equipped with ventilation fans, smoke, heat, or flammable gas detector

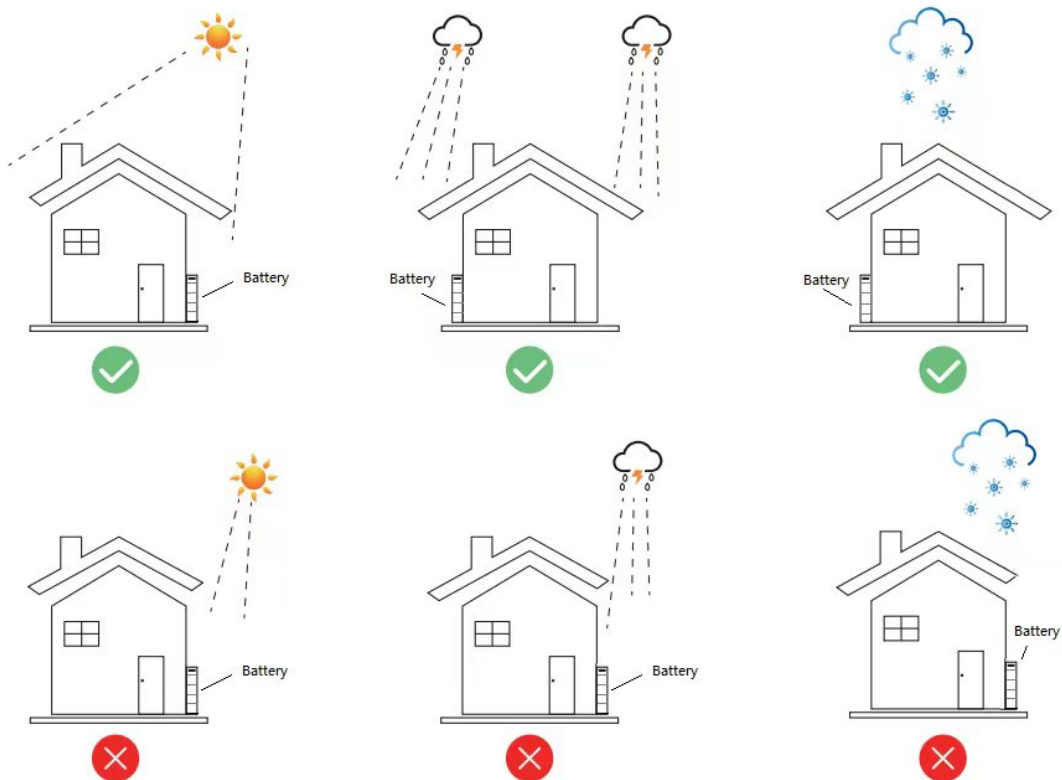

Honor ES performance degrades when ambient temperature is below 10°C(50°F) or above

40°C(104°F) degrees.

### 3.2 Installation physical requirements

a. Item inspection

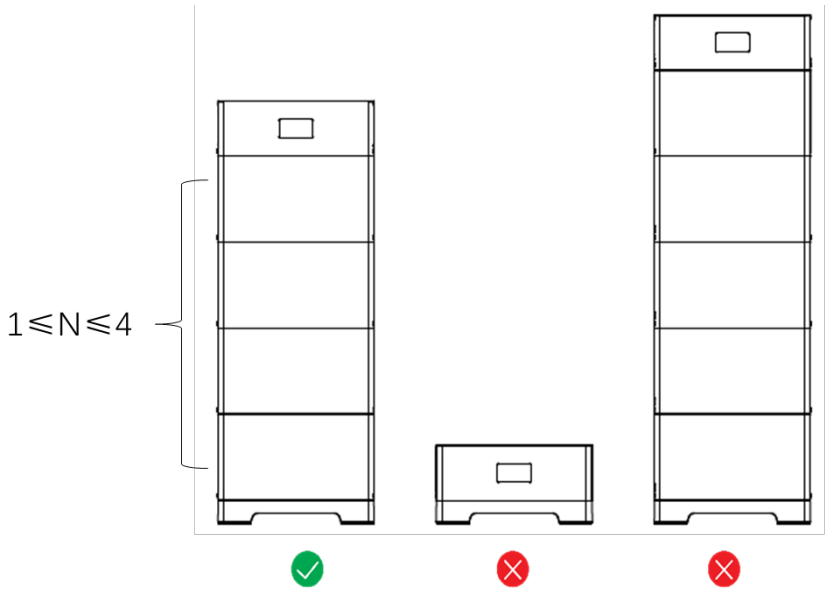

**b. Installati**

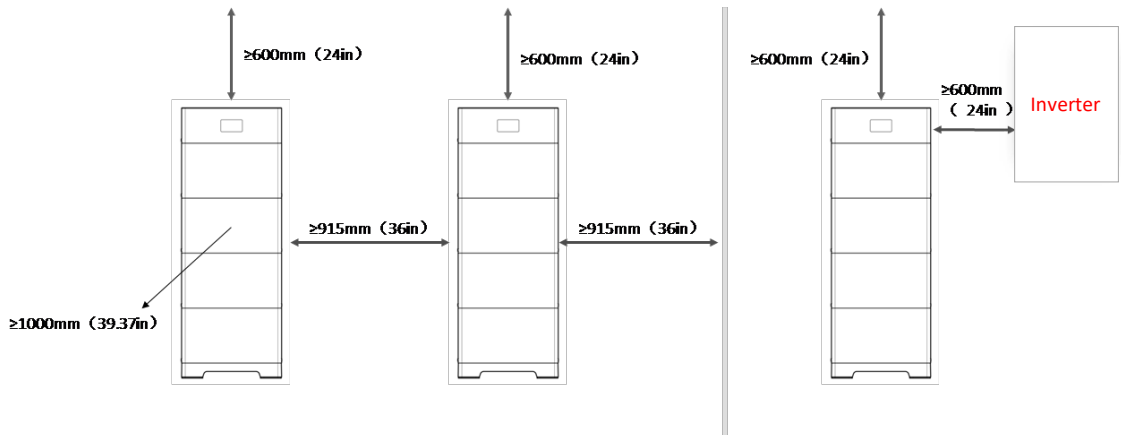

**c. Level control**

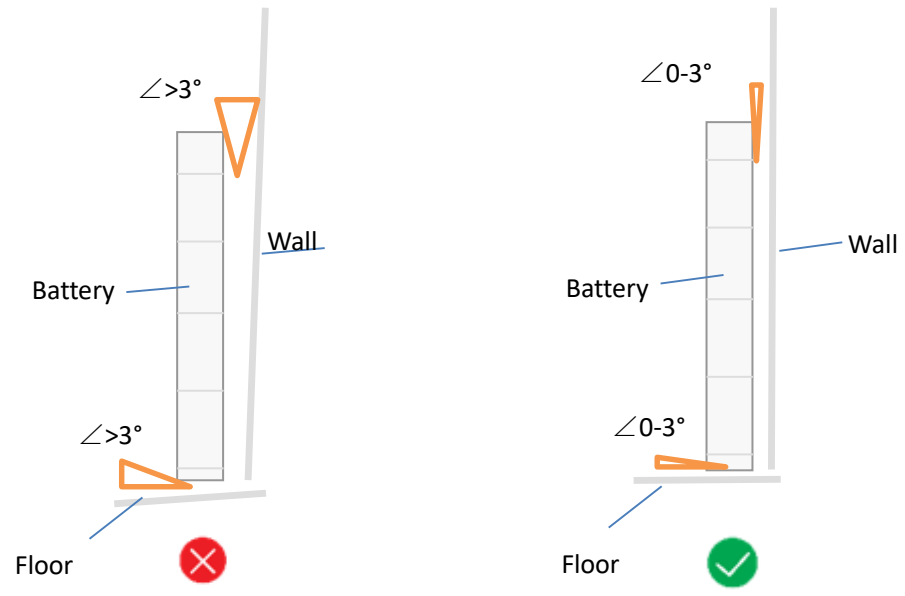

#### d. L-bracket fixing bolt positioning

Take into account the actual surface condition before fixing the L-bracket: the bolt spacing is 406 mm (16 inches) for the inner ones and 508mm (20 inches) for the outer ones, as illustrated below.

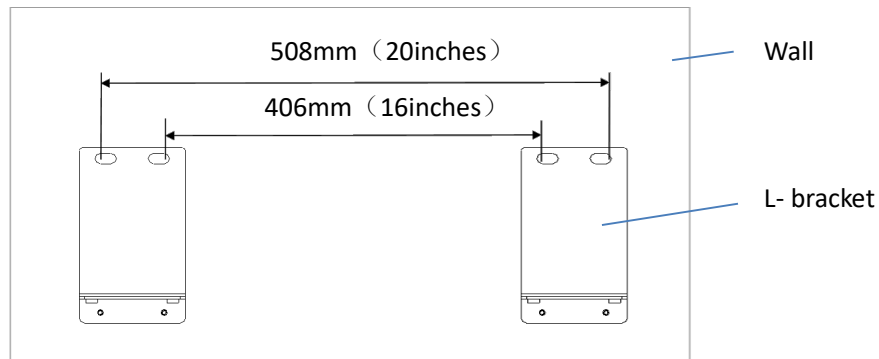





#### Prepare the wall-mounting surface before drilling





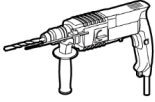
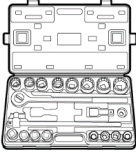

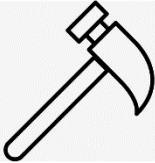
Avoid electricity wire, metal conduit or pipe inside the wall; consider using wall scanner (wall detector)

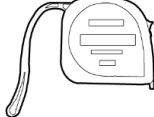
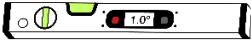
### 3.3 Installation



#### 3.3.1 Installation tools







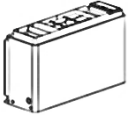

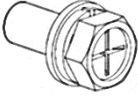
 Impact drill (3/8 & 13/64 drill)	 Torque wrench (7/16 & 9/16 hexagonal socket)	 Marker pen	 Electric batch
 Hammer	 Detector	 Steel tape	 Level ruler

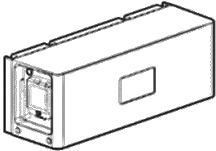
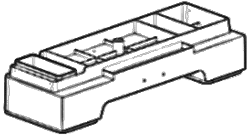
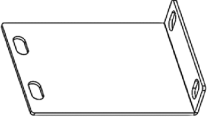
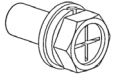
Personal Protective Equipment (PPE)

			
Safety gloves	Safety goggles	Dust mask	Safety shoes

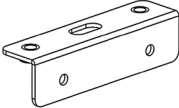
### 3.3.2 Packaging components

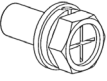
Battery Module Packaging Components		
		
Battery module X1	Screw cover X4	Fixing screws (M5*12) X4

Control Module Packaging Components			
			
Control module X1	Base X1	L-bracket X4(max)	Fixing screws (M5*12) X12(max)
			
Expansion screw M8*80 X4(max)	Self-tapping screws M6*60 X4(max)	M6*18*2large flat pad X4 (max)	Grounding Terminals X1
			
Angle bracket X4(max)	Screw cover X4	Fixing screws (M6*14) X8(max)	M8 flange nuts X4(max)
			
User manual X1			

Cable kit Packaging Components		
 Positive wire harness X1	 Negative wire harness X1	 PCS-RS485/CAN communication cable X1

### 3.4 Installation steps

**a. Place the base**

Take the control module and base module out of the carton and put them side by side.

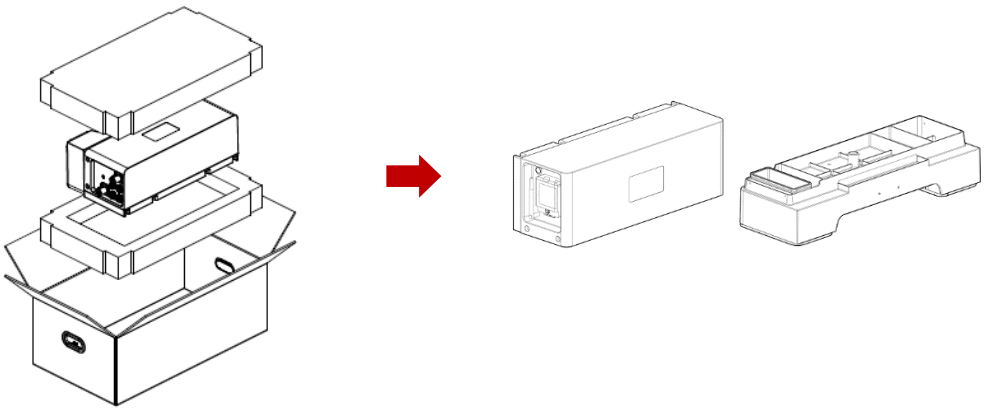

The base module should be placed on a level ground, parallel to the wall. The clearance to the wall should be 35mm (1.38inches).

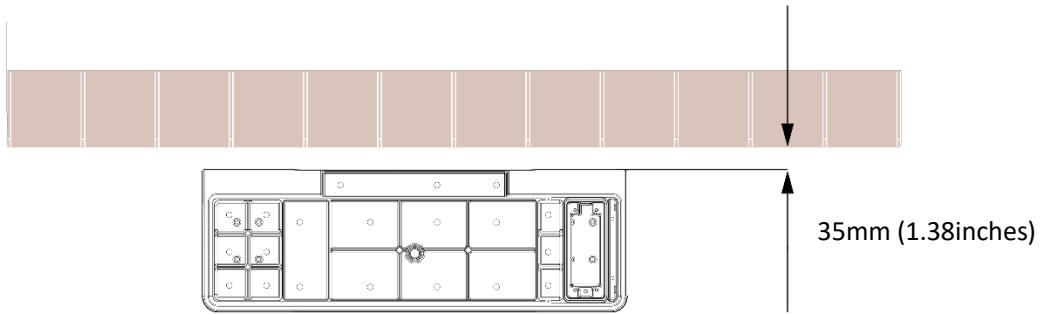

**b. Install the angle bracket**

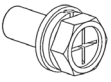
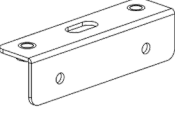
Fixing screw	M5*12	4 pcs	
Angle bracket	-	2 pcs	

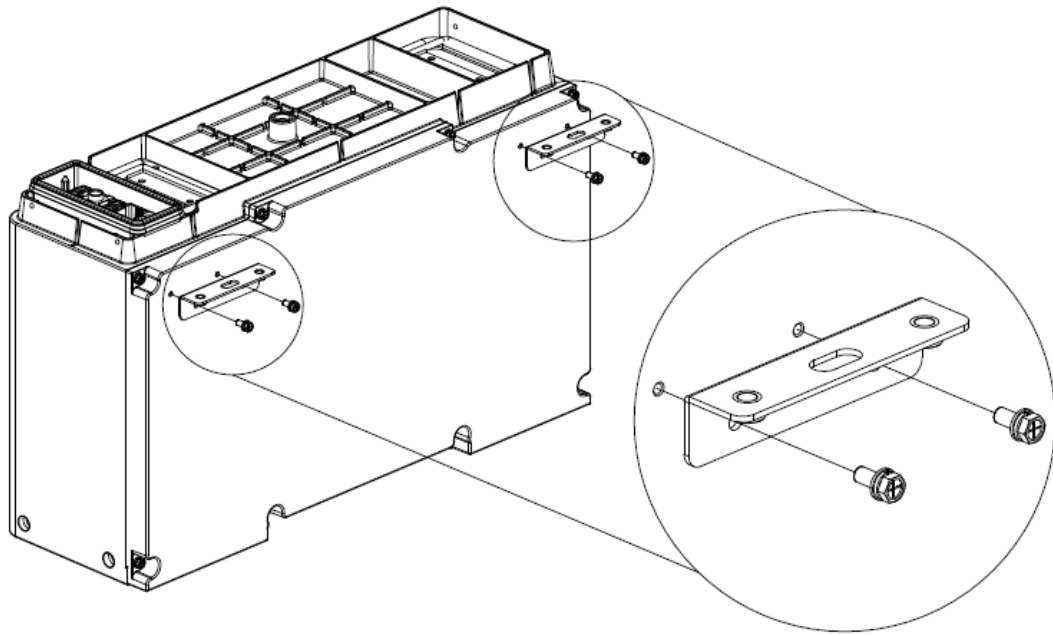

Refer to the following for the recommended the wall mounting assembly (angle bracket + L-bracket) installation:

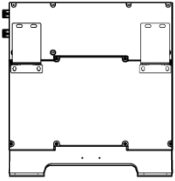
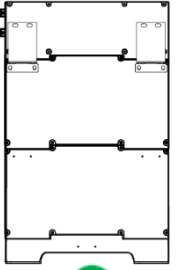
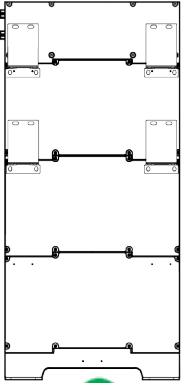
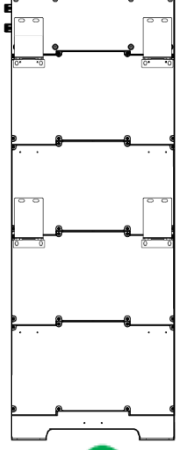
 <p style="text-align: center;">✔</p>	 <p style="text-align: center;">✔</p>	 <p style="text-align: center;">✔</p>	 <p style="text-align: center;">✔</p>
<p>1 mounting assembly on <b>Batt. No.1</b></p>	<p>1 mounting assembly on <b>Batt. No.2</b></p>	<p>2 pcs mounting assembly on <b>Batt. No.2</b> <b>Batt. No.3</b></p>	<p>2 pcs mounting assembly on <b>Batt. No.3</b> <b>Batt. No.4</b></p>

**c. Stack battery module**



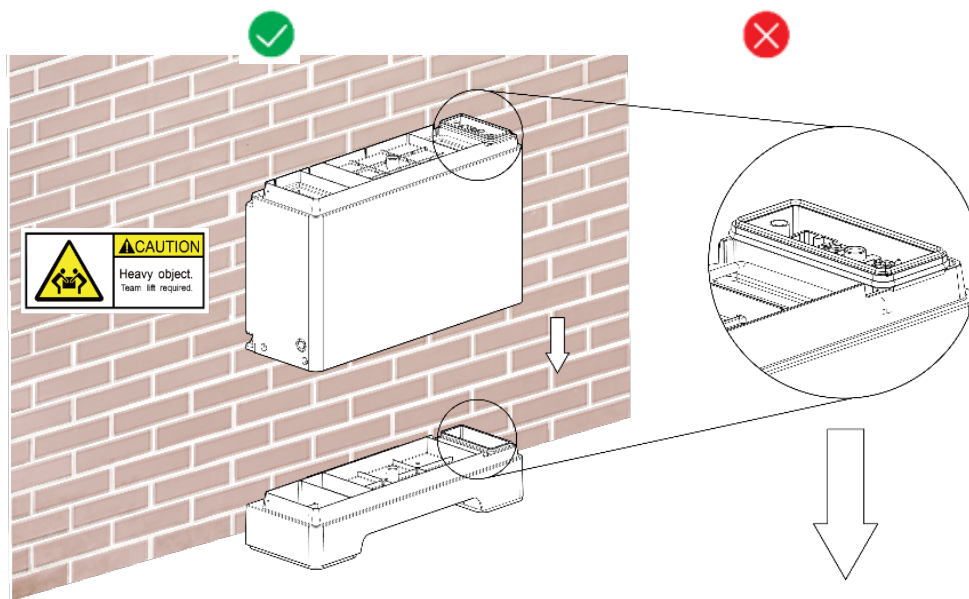
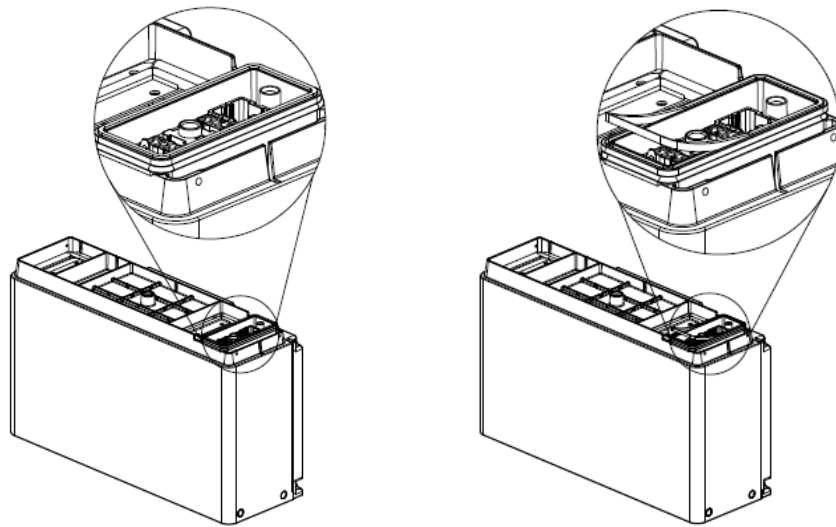

Before stack battery module, please check that the terminal sealing ring is well fixed.

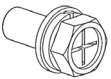

Unit weights 50kg (110.2lbs). Two or more people are necessary. Align the connector side first; then stack gently to avoid damaging the connector!

**Fasten the installed battery module**

Fixing screw	M5*12	4 pcs	
Screw cover	plastic	4 pcs	

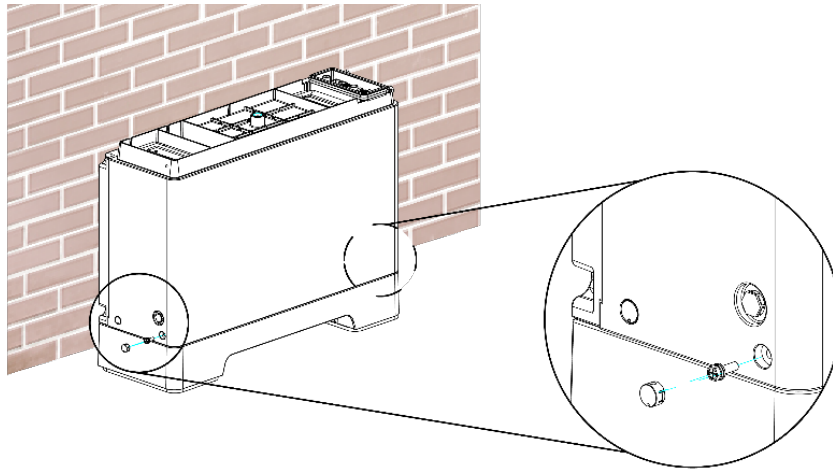

**d. Adding additional battery module**

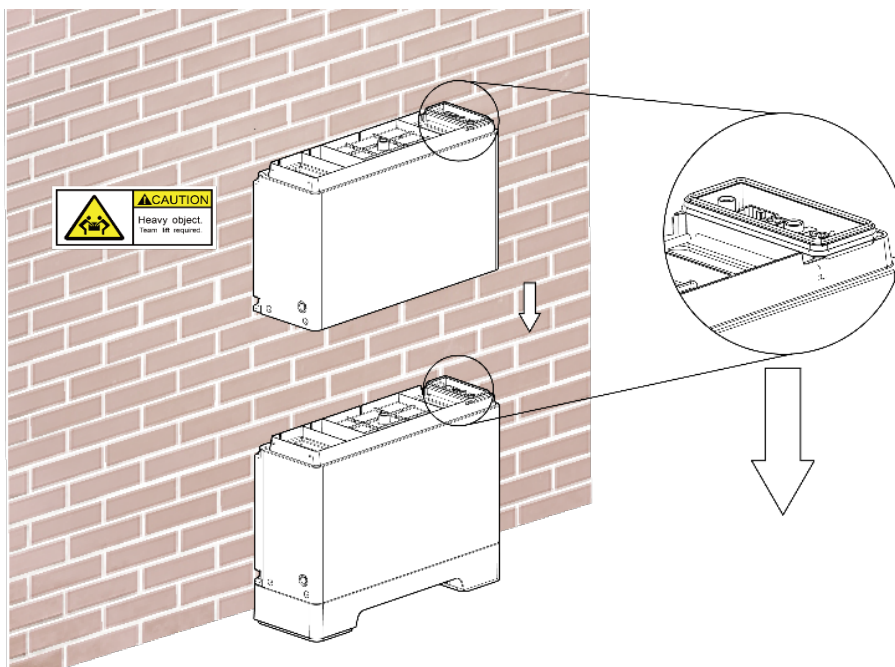

**Fasten the stacked battery module**

Fixing screw	M5*12	4 pcs	
Screw cover	plastic	4 pcs	



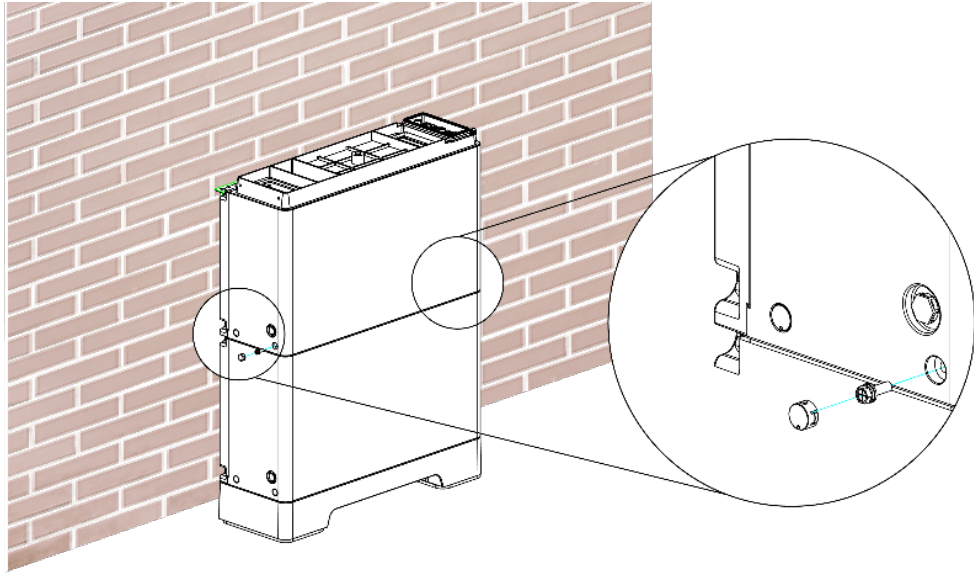

**e. Install L-bracket**

L-bracket	-	2 pcs	
-----------	---	-------	---

① Mark the screw position

Place the L-shaped bracket against the wall on the L-bracket and mark the drilling point

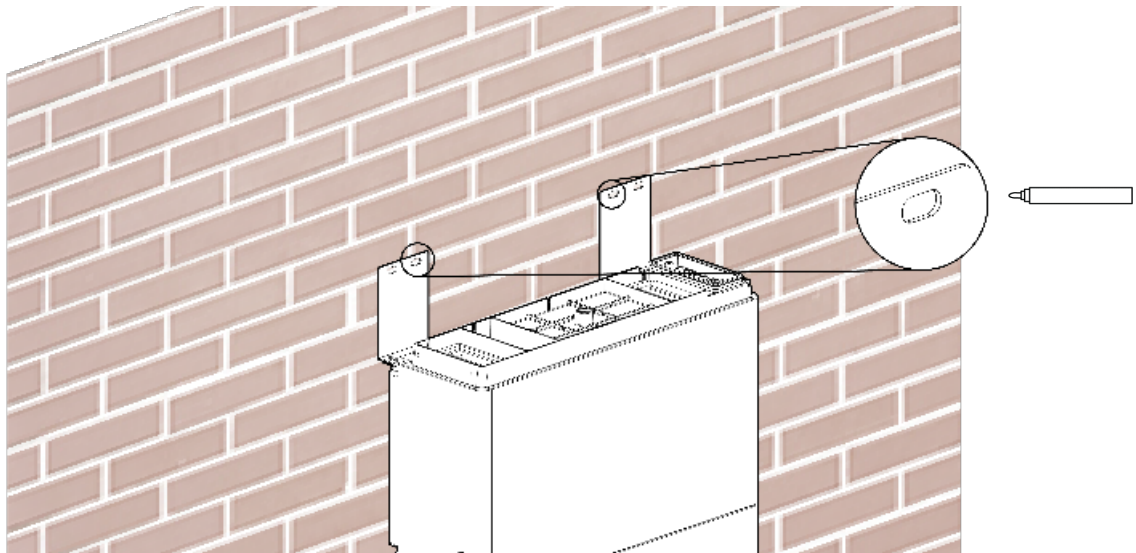



② Drilling (for concrete or brick wall) and fixing the L-Bracket to the wall

Use PE bag from the product packaging to prevent falling debris.

Case 1 for concrete wall or brick

Expansion screw	M8*80	2 pcs	
Flange nut	M8	2 pcs	

Case 2 for wooden wall

Self-tapping screws	M6*60	2 pcs	
Large flat pad	M6	2 pcs	

Note: The self-tapping screw must penetrate the stake 38mm.

- 1, Use M6\*60 2pcs self-tapping screws to drill directly into the stake.
- 2, Use a 13/64 bit to pre-drill the holes if there are concrete wall partitions in front of the stakes.

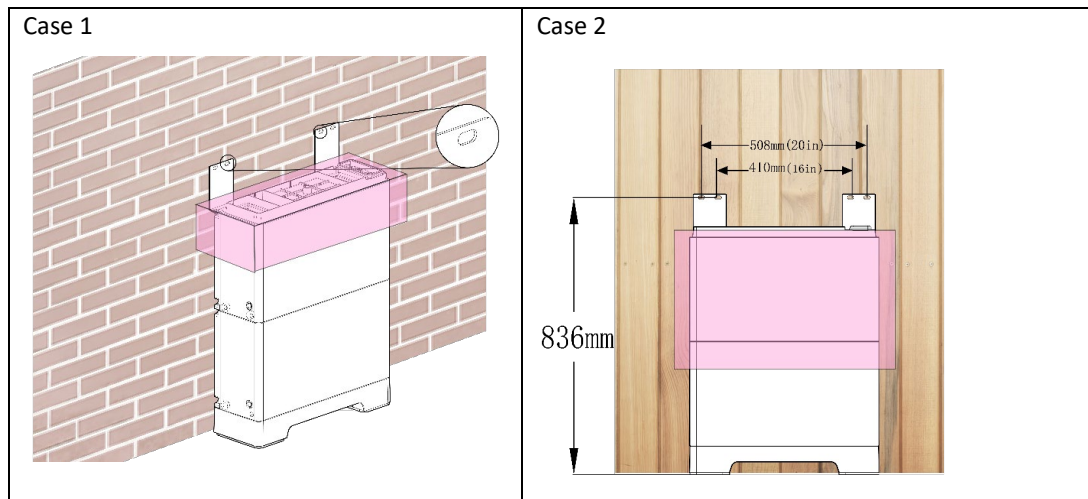

Make sure the connector is clean from debris.

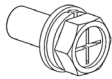

③ L-shaped bracket assembly

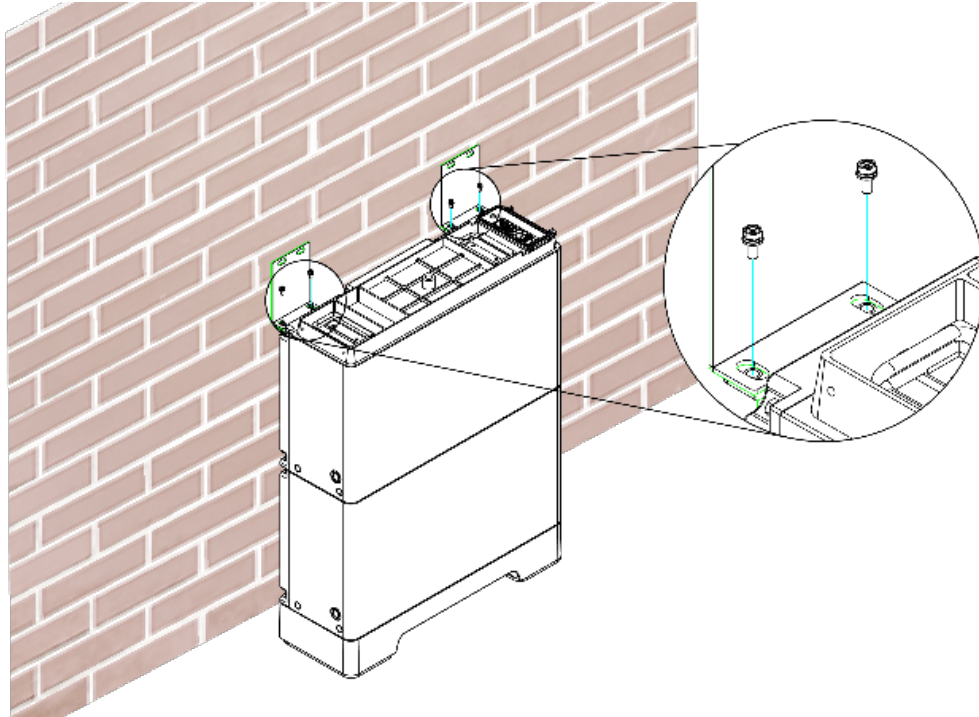
Hex screw	M6*14	4 pcs	
-----------	-------	-------	---



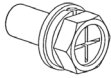

**f. Stack additional battery modules (up to 4 battery modules in total)**

Fasten the stacked battery module

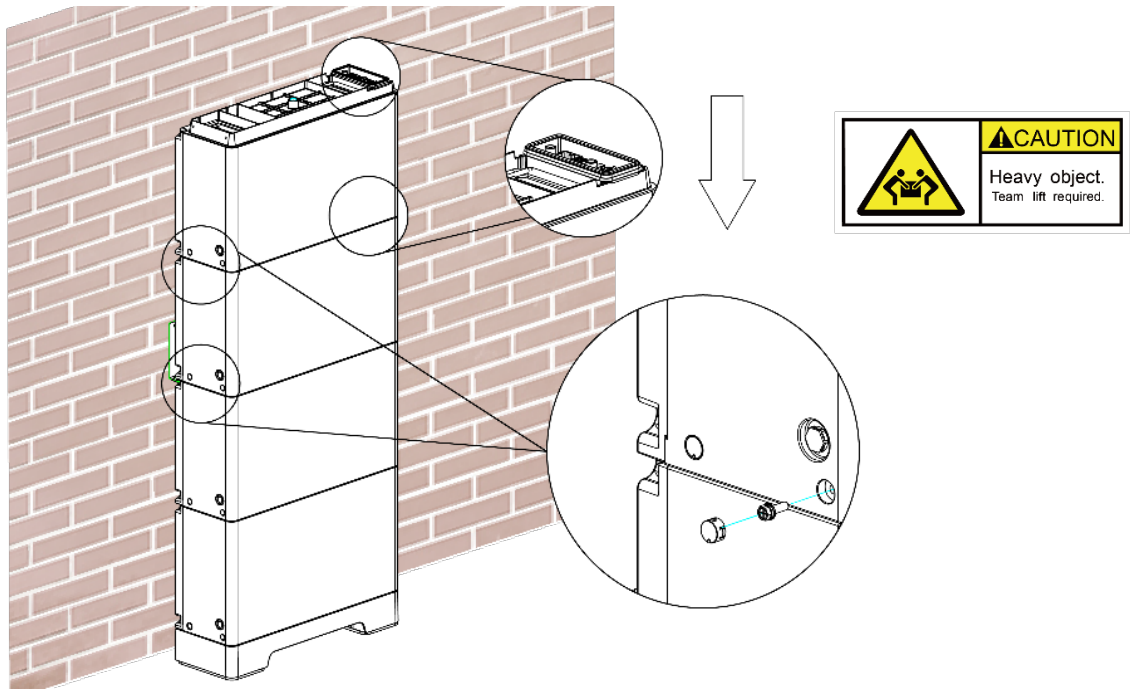
Fixing screw	M5*12	8 pcs	
Screw cover	plastic	8 pcs	



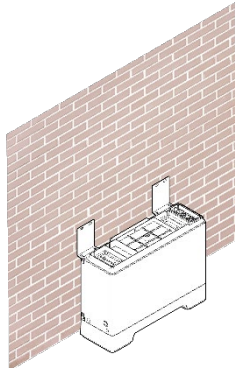

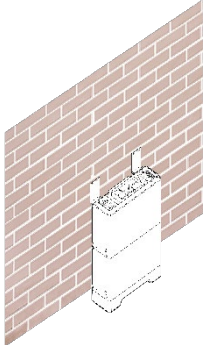
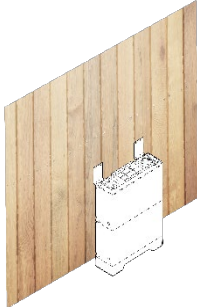
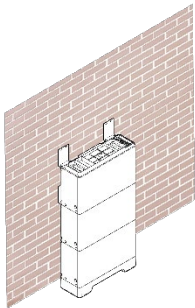
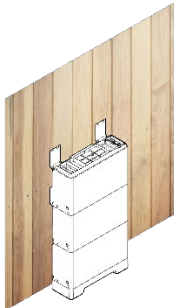
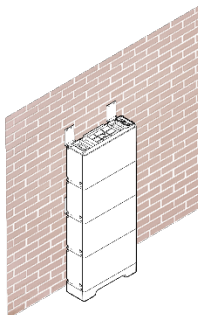
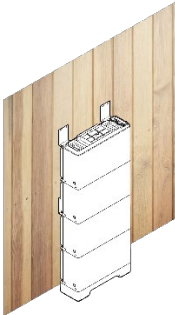
**g. The overall bracket completes the installation position arrangement**

Honor ES RY-5-S1		Honor ES RY-10-S1	
Concrete wall 	Wooden wall 	Concrete wall 	Wooden wall 
Honor ES RY-15-S1		Honor ES RY-20-S1	
Concrete wall 	Wooden wall 	Concrete wall 	Wooden wall 

## h. Control module installation

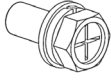
### ① Fasten the stacked battery module

Fixing screw	M5*12	4 pcs	
Screw cover	plastic	4 pcs	

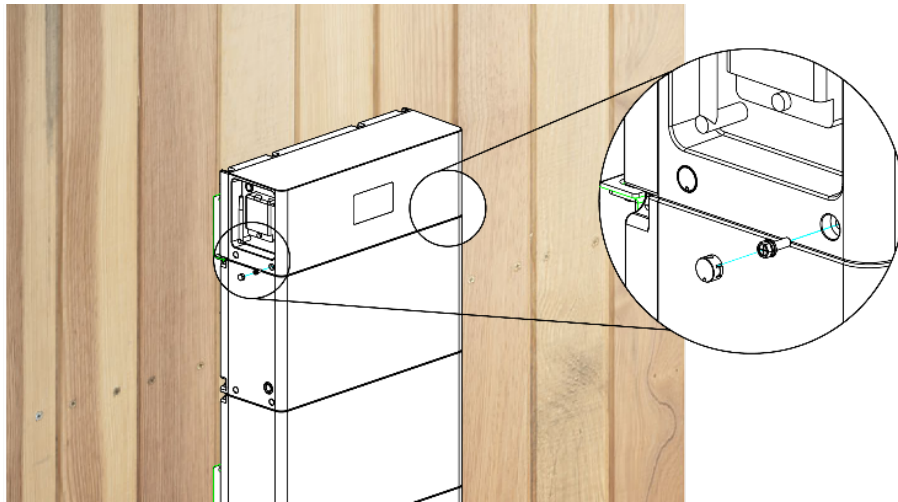

### ② Check model

Tick the nameplate model according to the number of installed battery modules:

5kWh: Honor ES RY-5-S1	10kWh: Honor ES RY-10-S1
15kWh: Honor ES RY-15-S1	20kWh: Honor ES RY-20-S1

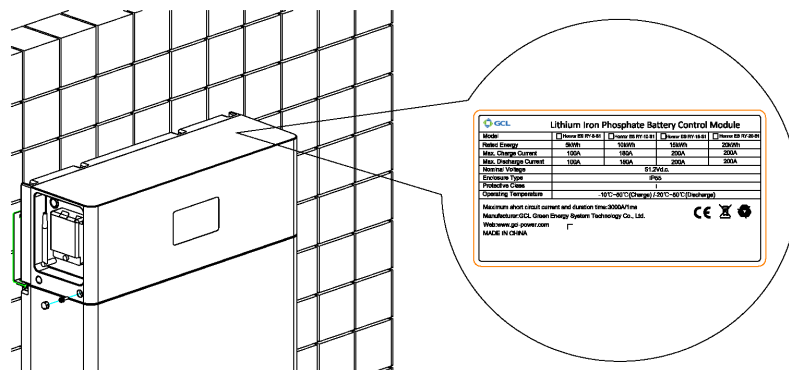



---

**i. Installation Accomplish**

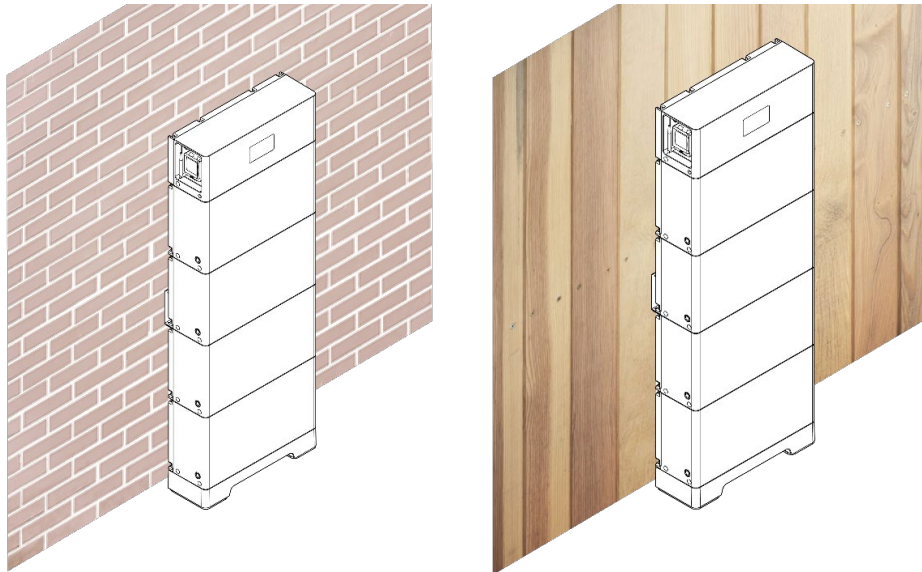

## 4 Electrical connections



Do not power on the system during electrical connection.



Note: Before wiring, check whether the circuit breaker on the left side of the battery system control box is disconnected.

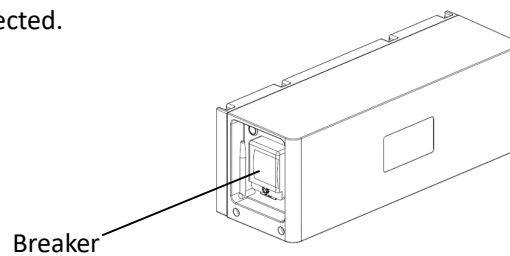

Note: For Australian market a overcurrent protection and isolation devices that isolates both positive and negative conductors simultaneously is required between the inverter and the battery system and between parallel battery systems.

### 4.1 Grounding instructions

The recommended grounding cable specifications are as follows.

Ground cable	8AWG (yellow-green)
Ring terminal	M5
Screw	M5

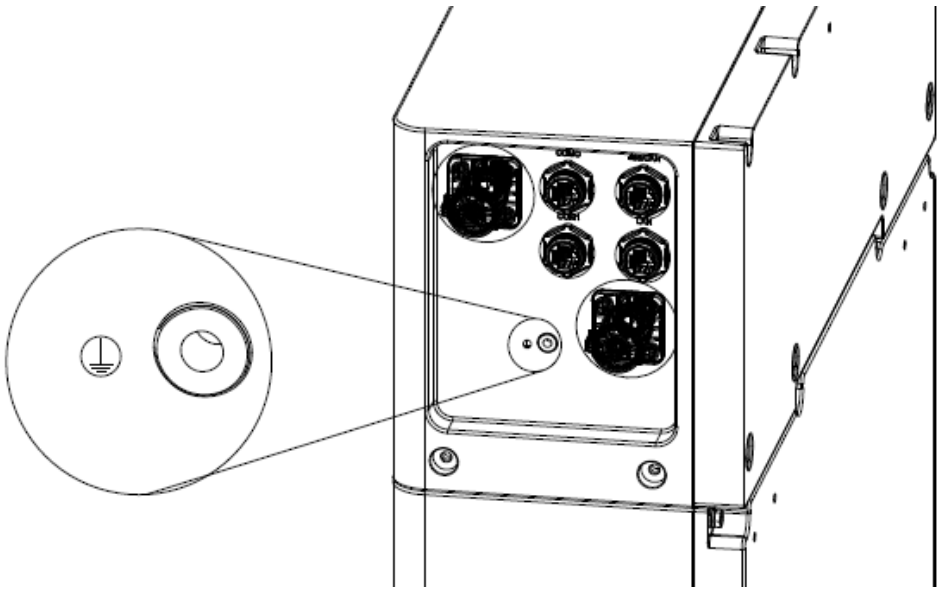
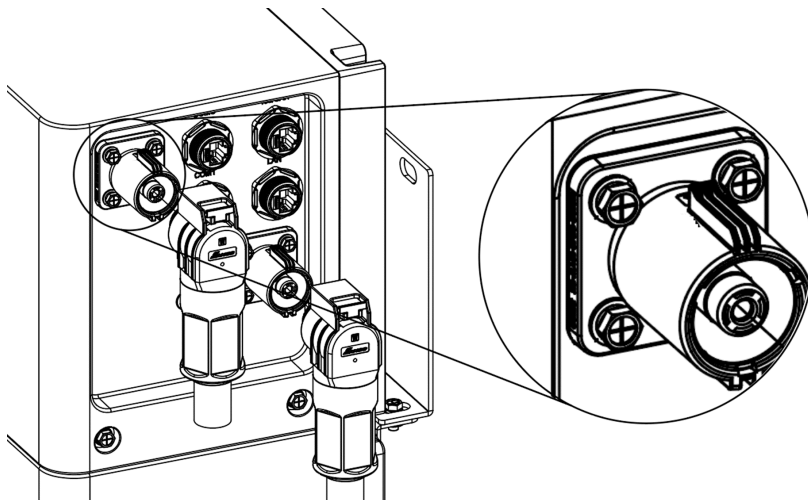
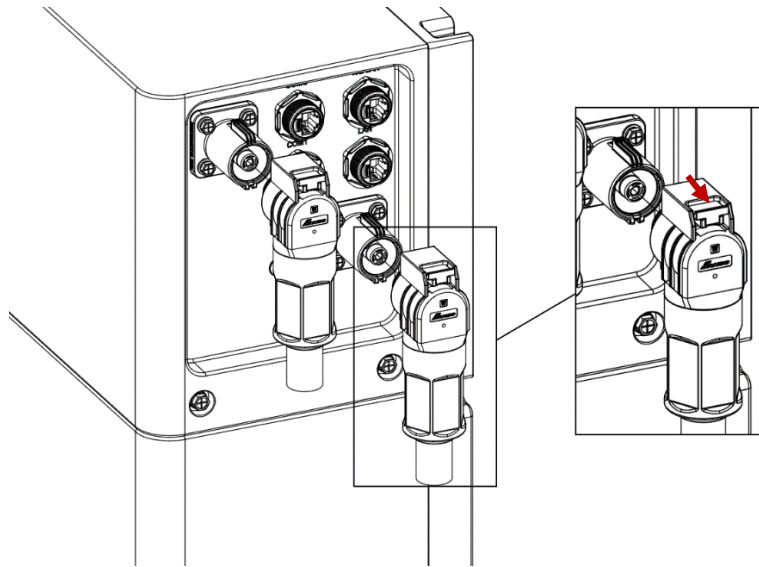

Figure 4-1-1 Schematic diagram of equipment grounding

## 4.2 Power connector installation



a. makes sure the red/black buckle is released before insertion.



**b. Lock the connector by pushing forwards the red/black buckle after insertion**

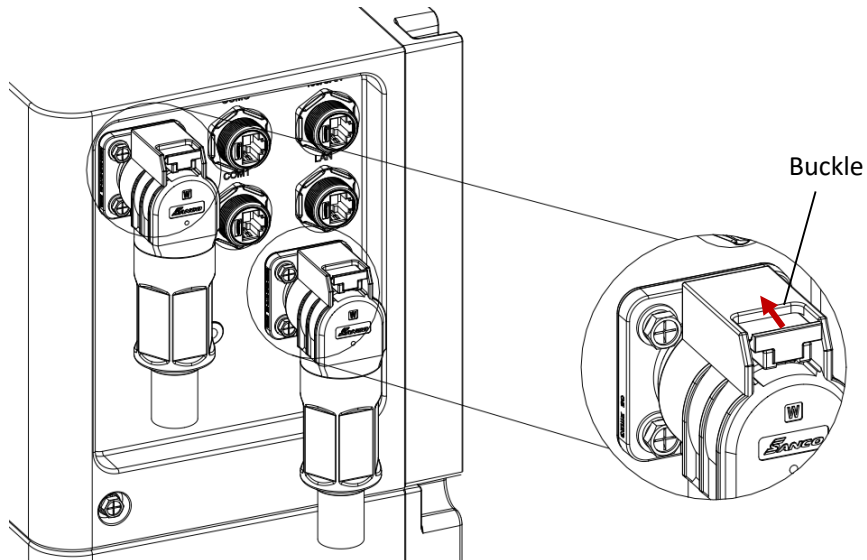

## 4.3 Cable connection

### 4.3.1 Single Horror ES system



Refer to user manual for inverter connection.



Check step

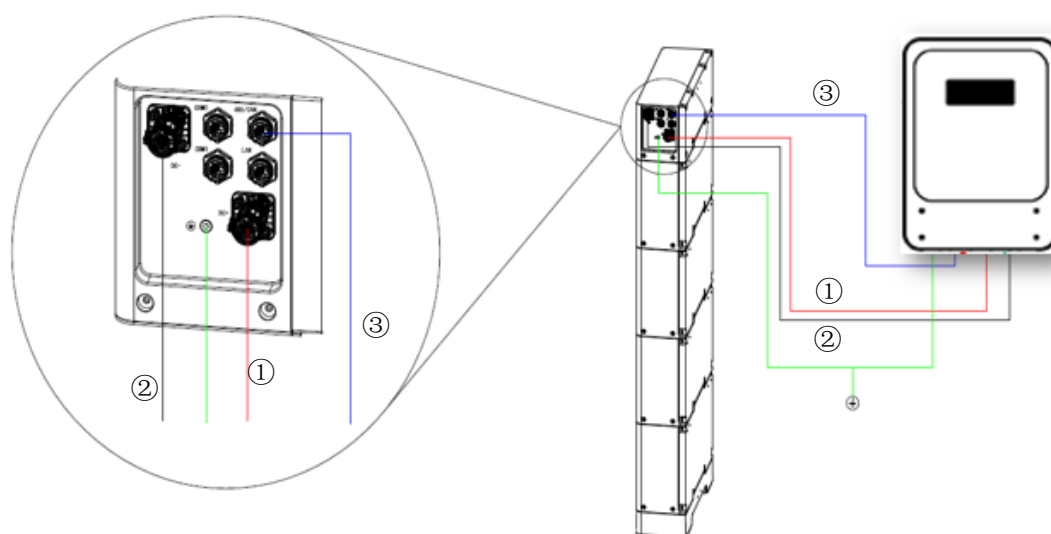

Figure 4-3-1 Wiring diagram of single machine system

No.	Harness name	Cable mark
①	To PCS positive wire harness	DC+ PCS to BAT+
②	To PCS negative wire harness	DC- PCS to BAT-
③	To PCS-RS485/CAN communication cable	BAT to PCS

RS485/CAN port pin definition of the control module:

Color	Port	Pin	Function
Orange-white		1	RS485A
Orange		2	RS485B
Green- white		3	
Blue		4	CANH
Blue- white		5	CANL
Green		6	
Brown-white		7	
Brown		8	

### 4.3.2 Multiple Honor ES in parallel

Up to 3 pcs Honor ES can be connected in parallel. The power conductor of the combined Honor ES output shall be according to the total current rated.



Consider using a combiner box when combining positive and negative output from multiple Honor ES RY-5/10/15/20-S1 as illustrated below. Choose proper conductor / cable in a way that the current during normal or fault condition (fault current) do not lead to excessive heating of the material or fire hazard.

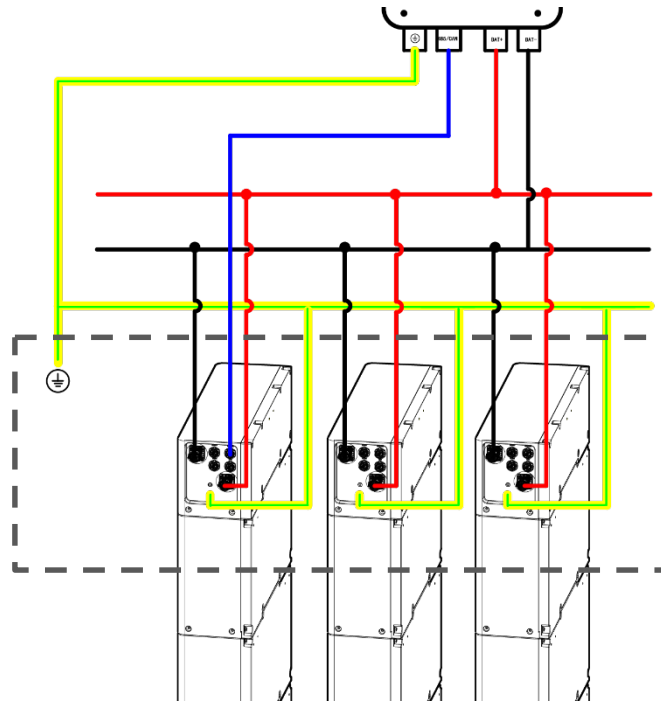

**Figure 4-3-2a Wiring diagram of parallel system (dashed square represents the combiner box)**

For inverter communication, only the **CAN/RS485** on the master unit needs to be connected. Communication between Honor ES RY-5/10/15/20-S1 is by connecting **COMM0** (slave-side) to **COMM1** (master-side) as illustrated below.

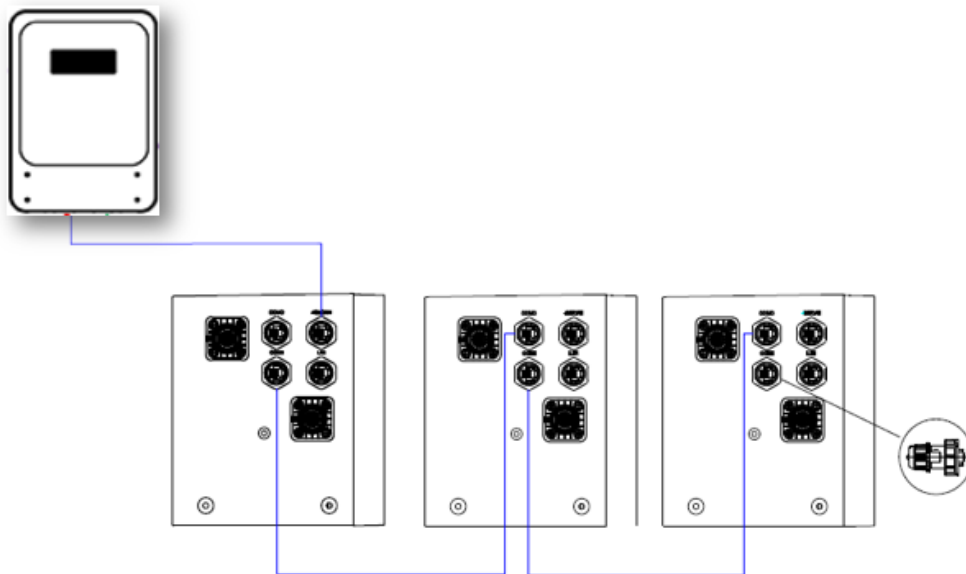

**Figure 4-3-2b Communication wiring of multiple system**

## 5 Power up your system



Checked all connections thoroughly before proceeding.



Refer to user manual for inverter operation.

## 5.1 System power up

- Close breaker/switch disconnecter between inverter and battery ①
- Close the control module circuit breaker ② (MCB).
- Press and hold the POWER button ③ for more than 3s.

The POWER button lights up, the output is enabled and the display interface lights up.

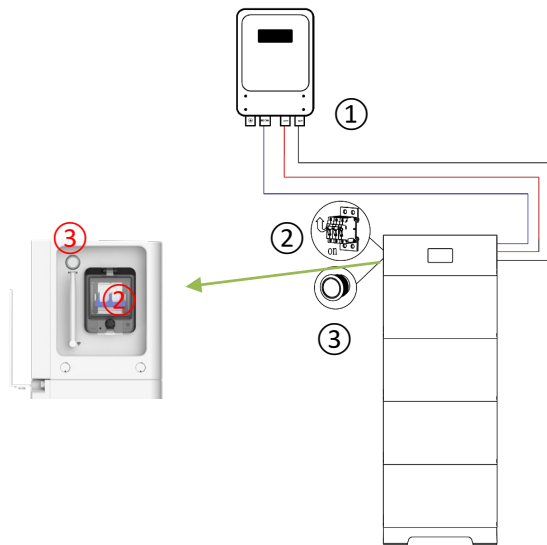

Note: Each cluster of battery systems in parallel system is powered on independently.

## 5.2 System power off

- Open the breaker/switch disconnecter between inverter and battery ①.
- Press and hold the POWER button ③ for more than 3s.
- Disconnect the battery side MCB ②.

The system disable output. Both Power button led and the display goes off.

Note: Each cluster of battery systems in parallel system is powered off independently.

## 5.3 Display description

- The display will automatically turn off after idling for 10 minutes.  
Short press the POWER button (1s) to wake up the display.

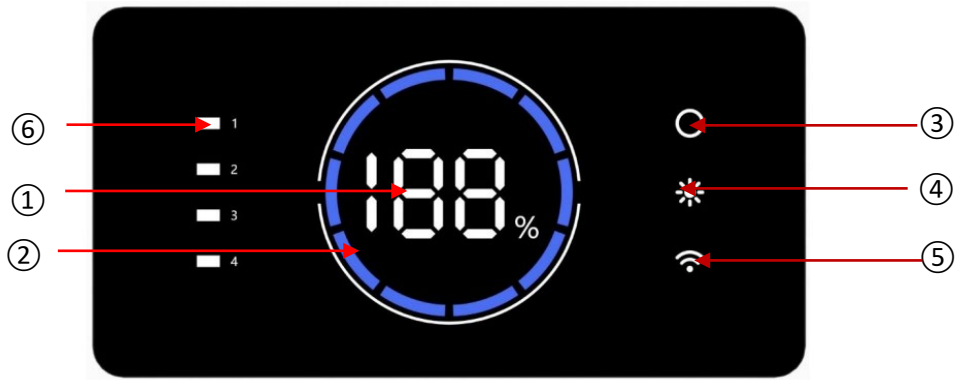

Table 5-3-1 Display

Item	Description	Function
①	SOC	Digital display of real-time state of charge (SOC)
②		[Constant on] discharging / idling, lit-up blue bar shows SOC. [Flashing] charging (last bar in counterclockwise direction)
③	System status	[Constant on] normal [Flashing] system fault
④	Heating state	[Constant on] heating function activated, [Off] heating function is not activated
⑤	Network status	[Constant on] Wi-Fi network connection successful [Flashing] Wi-Fi network is not connected
⑥	Battery module status	[constant on] battery module is normal [Flashing] battery module fault

## 5.4 System configuration

- a. Download and install PowerLite APP

The battery parameter setting and remote monitoring can be realized through the APP software (PowerLite), please go to the App Store or Google Play to search for "PowerLite" to download and install.

- b. Network configuration

- 1) Turn on the Wi-Fi and Bluetooth signal on your phone
- 2) Click Register to go to register an account

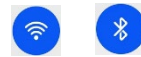

Enter the registration interface and fill in the information, after receiving the verification by email, enter the verification code to complete the registration.

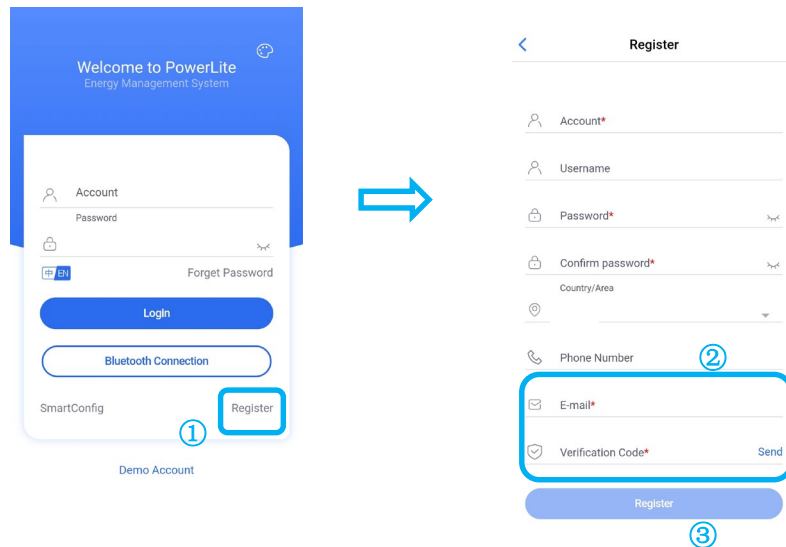

Note: If you have already registered a login account, please ignore this step.

### 3) Configure the network

(You can check the Bluetooth SN code of the battery device at the antenna position of the control module)

①Click "SmartConfig", ②Select the Bluetooth device corresponding to the battery, ③Enter the WiFi network account and WiFi password, ④Click "SmartConfig" to complete the networking, the APP displays the successful network configuration information and the WiFi icon on the display is always on, that is, the network configuration is completed.

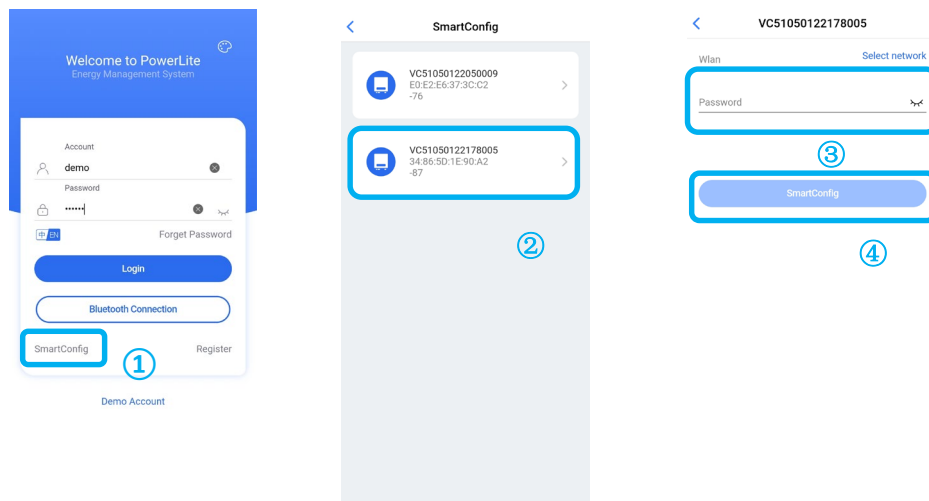

### c. Add site/device

(Please check the battery equipment SN on the control box)

Enter the account, password and verification code, ①Click "Login" to log in. ②After logging in, click on the top right corner of the main interface to add a site, ③After recommending a power station, then add equipment, ④ select the SN code on the nameplate of the control module to add, ⑤And simultaneously click "Assigned Plant" to bind the battery equipment to the established power station, complete the site/device addition.

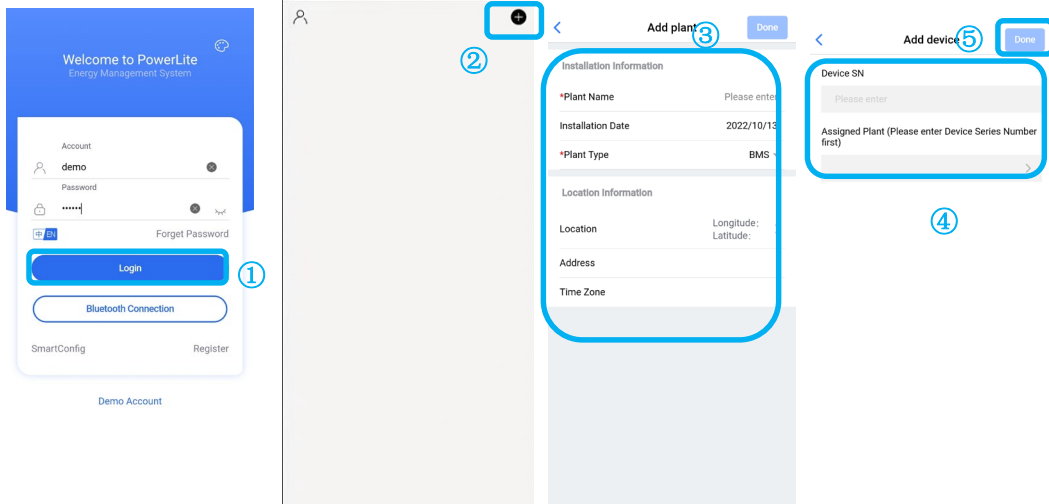

d. Select inverter manufacturer

After the site/device is added successfully, ①Click to enter the corresponding site, ②Click the Bluetooth SN code of the battery device to enter the battery interface, and you can view the device data, ③Click “Setting” to enter the inverter manufacturer interface for selecting the battery system configuration, ④Select After the inverter manufacturer is successfully set, the system configuration is completed.

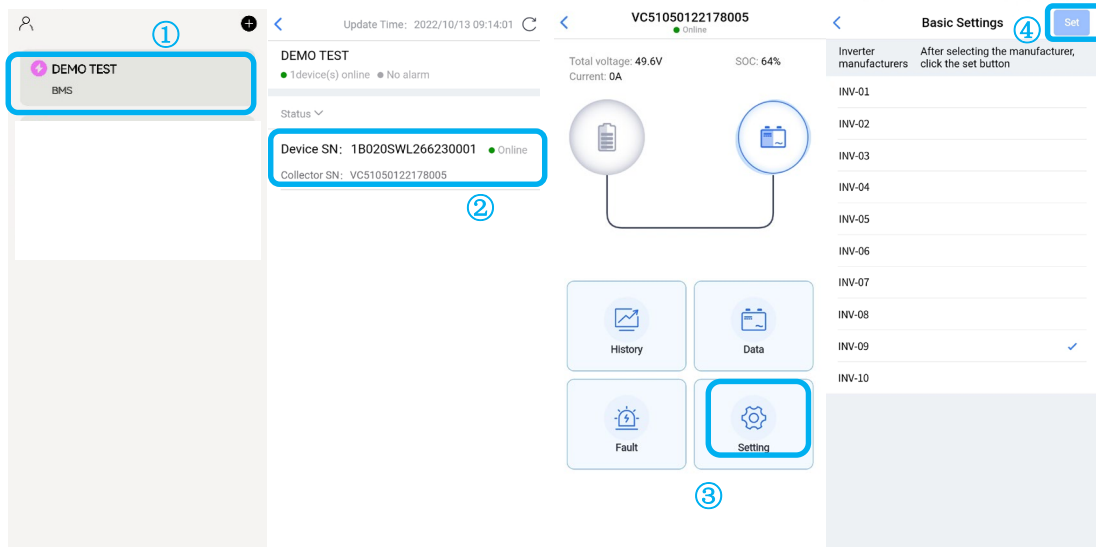

Inverter manufactures	APP setting
Default	INV-01
Sacolar	INV-02
Goodwe	INV-03
Deye	INV-04
SMA	INV-05
Victron	INV-06
Solis	INV-07
Selectronic	INV-08

MEGAREVO	INV-09
LUXPOWER	INV-10

## 6 Maintenance and troubleshooting

### 6.1 Routine maintenance

- Maintenance charge every 6 months

From the date of manufacturer shipment, the battery shall be maintained every 6 months. Action must be taken in case SOC reaches 0% according to,

Ambient temperature	Must be recharged within
(45, 50] °C	7 days
(35, 45] °C	15 days
≤35°C	30 days

- Disconnect the battery if not being used

BMS consumes power even when the battery is not being used. Disconnect the battery output to prevent the battery from becoming empty. For store-away, make sure the SOC is between 45% and 55% before disconnect.

- Check the battery system regularly. Contact your support if any anomaly detected.

### 6.2 Fault checklist

Fault	Cause	Solution
POWER button no response	Damaged POWER button Damaged cable or poor contact	Repair or replace the control module Please contact the supplier
Short discharge time	battery SOC is low	Keep the product charged continuously and keep the energy storage battery system fully charged
	low ambient temperature	Guarantee the product to work within the recommended suitable temperature range
	Product overload	Check load status and remove non-essential loads
	Batteries age and capacity decreases	To replace the battery, please contact the supplier for the battery and its components
Unable to charge and discharge	Internal failure	Log in to the PowerLite APP to view the fault information and contact the supplier
	Battery report charging or discharging protection failure	Log in to the PowerLite APP to view the fault information and contact the supplier
	After the battery is discharged to the SOC protection value, it needs to be charged for a period of time	The battery is charged to the SOC value set by the restart

	before it is allowed to discharge.	
	battery over temperature	Stand at room temperature for more than 3 hours
After the system is powered on, the display cannot be lit or the displayed content is abnormal	Display failure	1.Please try restarting the battery 2.Please contact the supplier to repair or replace the control module
The display cannot wake up and light up during system operation	1. If the POWER button light is off, the POWER button is faulty or the button wiring is loose 2. If the display still does not light up after restarting, the display is faulty	1. Log in to the PowerLite APP to view the fault information 2. Please try restarting the battery 3.Please contact the supplier to repair or replace the control module
Abnormal battery communication	Communication disconnection	Check whether the battery stack is installed reliably, and confirm the abnormal battery through the battery status indicator on the display
The system status light on the display is abnormal and blinks every 1S	other	Log in to the PowerLite APP to view the fault information and contact the supplier
The heater works abnormally, and the heating status indicator on the display flashes every 1S	Heating circuit failure	Log in to the PowerLite APP to view the fault information and contact the supplier
Abnormal Bluetooth connection	1.bluetooth account connect error 2. Bluetooth connected to other devices	1.Check whether the paired Bluetooth is consistent with the installed product 2. Disconnect Bluetooth from other devices
Abnormal WiFi connection	1. The WiFi connection is misconfigured 2. The WiFi module is abnormal and the line connection is abnormal	1. Check if the battery WiFi connection configuration is correct 2. Check whether the antenna is installed or connected reliably
The inverter is powered on for the first time through the battery, and the battery reports short-circuit protection	The parallel capacitor value of the input terminal on the battery side of the inverter is large	1.Battery protection can be automatically restored 2. Please try restarting the battery
Inverter won't start	The battery voltage is too low or the SOC is lower than the shutdown protection value	Charge the battery after starting the inverter from the grid



---

## 7 Warehouse storage guidelines

### 7.1 Packaging guidelines

Lithium-ion batteries is recognized as dangerous goods. The packaging requirements for battery products are as follows:

- a. The packaging manufacturer with the packaging qualification for dangerous goods is responsible for providing product packaging, and the packaging manufacturer has a record in the local Commodity Inspection Bureau;
- b. After the packaging manufacturer completes the packaging, the supplier needs to apply to the Commodity Inspection Bureau, and the Commodity Inspection Bureau will provide the "Dangerous Package Product Use Inspection Sheet" and
- c. "Dangerous package product performance inspection sheet", and complete the dangerous package commodity inspection;
- d. All battery packs should be packaged with product instruction manuals. The packaged product should be placed in a dry, dust-proof and moisture-proof packing box;
- e. The product name, model, quantity, gross weight, manufacturer, and ex-factory date should be marked on the outside of the packing box.
- f. The necessary signs such as "upward" and "fear of fire" shall meet the requirements of GB/T 191;
- g. The packing method is: packing in a carton with molded foam buffer material in the carton;
- h. Accessories packaging: single accessories are first fastened with cardboard or plastic film or braided straps, neatly placed in the carton, and filled with regular fillers (foam pads, cardboard, etc.) to prevent the accessories from shifting in the box. The following documents should be included with the product when leaving the factory:
  - 1) Product certificate (both in Chinese and English);
  - 2) Product use (installation) manual (both in Chinese and English);
  - 3) Product packing list (both in Chinese and English);
  - 4) Factory inspection report (both in Chinese and English).
- i. Clean battery

Regular cleaning of the battery system is recommended. If the case is dirty, use a soft dry brush or dust collector to remove the dust. Cleaning liquid materials include solvents, abrasives, etc. Corrosive liquids should not be used to clean the housing.

- j. Packaging step

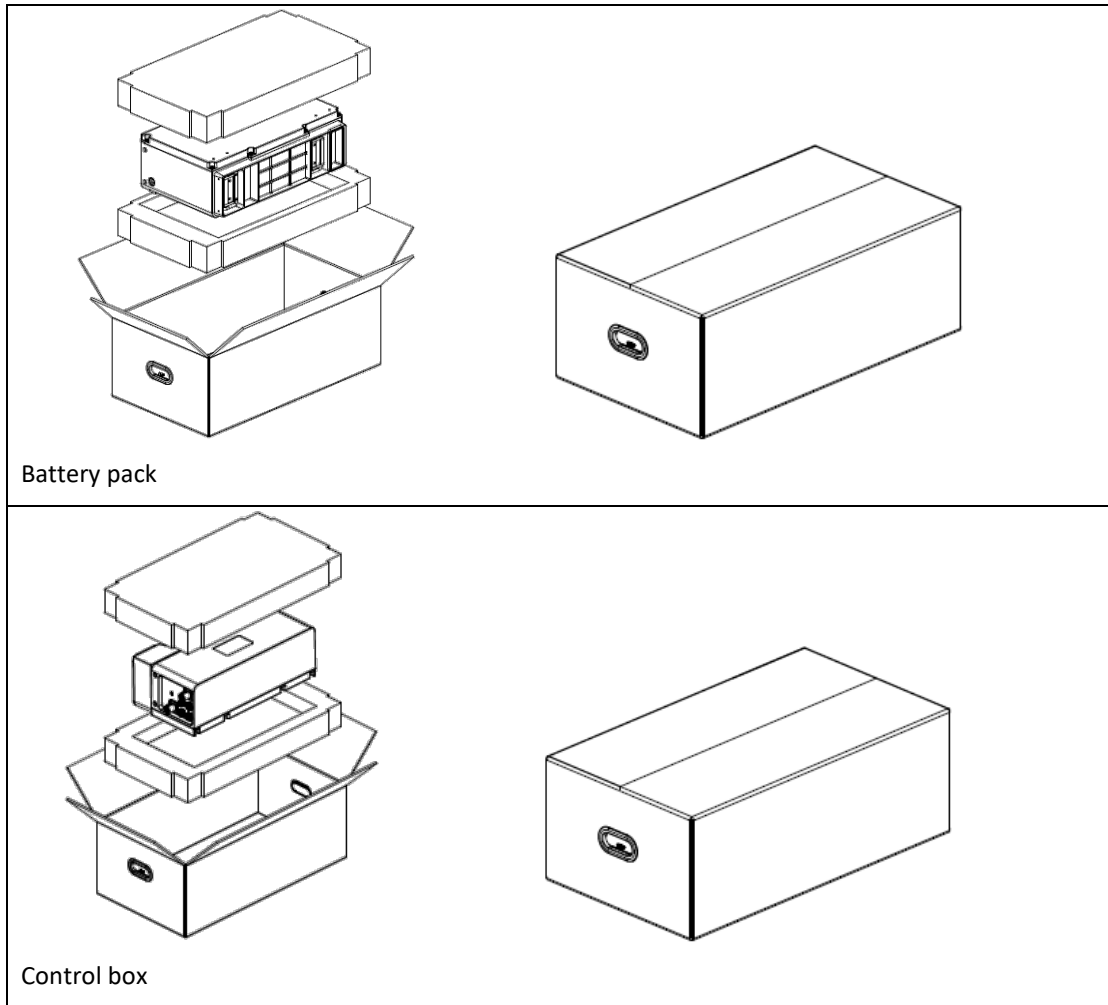

## 7.2 Storage

The battery pack is stored in a clean, dry and ventilated room with an ambient temperature of  $25^{\circ}\text{C}\pm 5^{\circ}\text{C}$  and a relative humidity of not more than 75%. The battery pack has a state of charge of 45% to 55%. Avoid contact with corrosive substances and keep away from fire and heat sources.

## 8 Dispose of used batteries

Comply with applicable local regulations for the disposal of electronic waste and used batteries.

- Do not mix with your household waste.
- Do not expose the battery to high temperatures or direct sunlight.
- Do not expose batteries to high humidity or corrosive environments.

Contact supplier or original manufacturer for disposal options.

## 9 Detailed specifications

### System Specifications

Item	Parameter			
Control module model	GCLH0K1200P03			
Rated voltage	51.2V			
Max. current	200A			
Battery module model	GCLB051100P03			
Cell Type	LFP			
Rated Voltage	51.2V			
Group method	16S1P			
Rated Capacity	100Ah			
Rated Energy	Honror ES RY-5-S1	Honror ES RY-10-S1	Honror ES RY-15-S1	Honror ES RY-20-S1
No. of batt. module	1	2	3	4
Rated energy	5kWh	10kWh	15kWh	20kWh
Maximum discharge and charge current	100A	180A	200A	200A
Dimensions W*H*D mm	573*597*189	573*912*189	573*1227*189	573*1542*189
Net weight	65kg	115kg	165kg	215kg
Rated voltage	51.2V			
Operating Voltage	44.8V~55.2V			
External communication	CAN/RS485/WiFi			
Cycle life	6000 times (25°C, 0.5C/0.5C, 90%DOD, 70% remaining)			
Scalable	Up to 3 cabinets in parallel			
Protection class	IP55			
Operating temperature	Charging [-10,50] °C; Discharging [-20,50] °C			
Working humidity	10%~95%RH			
Working altitude	<2000m, >2000m derating			
Warranty	10 years			
Certification	IEC62619,CE,UL1973,UN38.3			

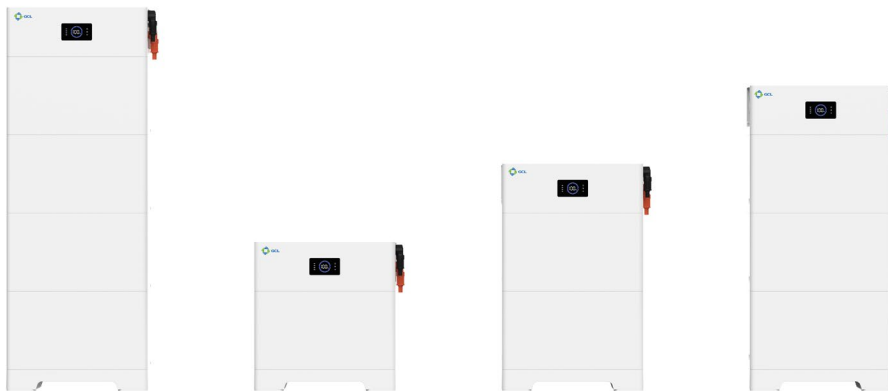

Honor ES RY-5/10/15/20-S1 Series



[www.gclsi.com](http://www.gclsi.com)

GCL Green Energy System Technology Co., Ltd.